



SATURN EVO 84200

SAFETY DEVICE



TECHNICAL FEATURES

- Manufactured in stainless steel
- Cylinder equipped with defender system
- Ergonomic key and cylinder tested with 56.000 open/close cycles
- Device always attached to the movable door
- Ergonomic shell for an easy and intuitive use
- Mounting instructions and fixing kit included

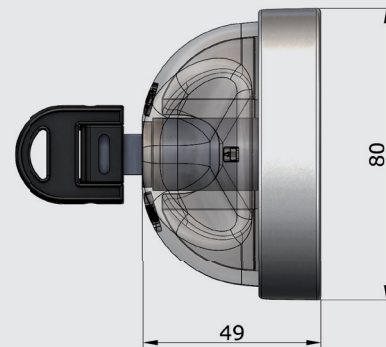

Saturn Evo is a van lock combining in a single device reliability, simplicity and flexibility. Saturn Evo is always attached to the door enabling the user to choose freely when to secure the cargo with the hands always free to work. Made in stainless steel, it is an excellent deterrent against intrusions. Available in keyed alike kits of two or three locks for the installation on rear and side doors.

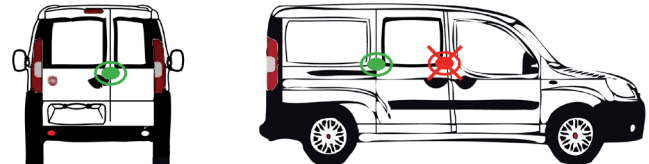

THE KIT CONSISTS OF

- n.1 Drill template
- n.2 Rubber protections for the van body
- n.2 Plastic shims
- n.2 Fixing plates
- n.1 External shell in stainless steel
- n.2 Keys
- n.1 Fixing kit

ASSEMBLY

